

PILE ELEVATION

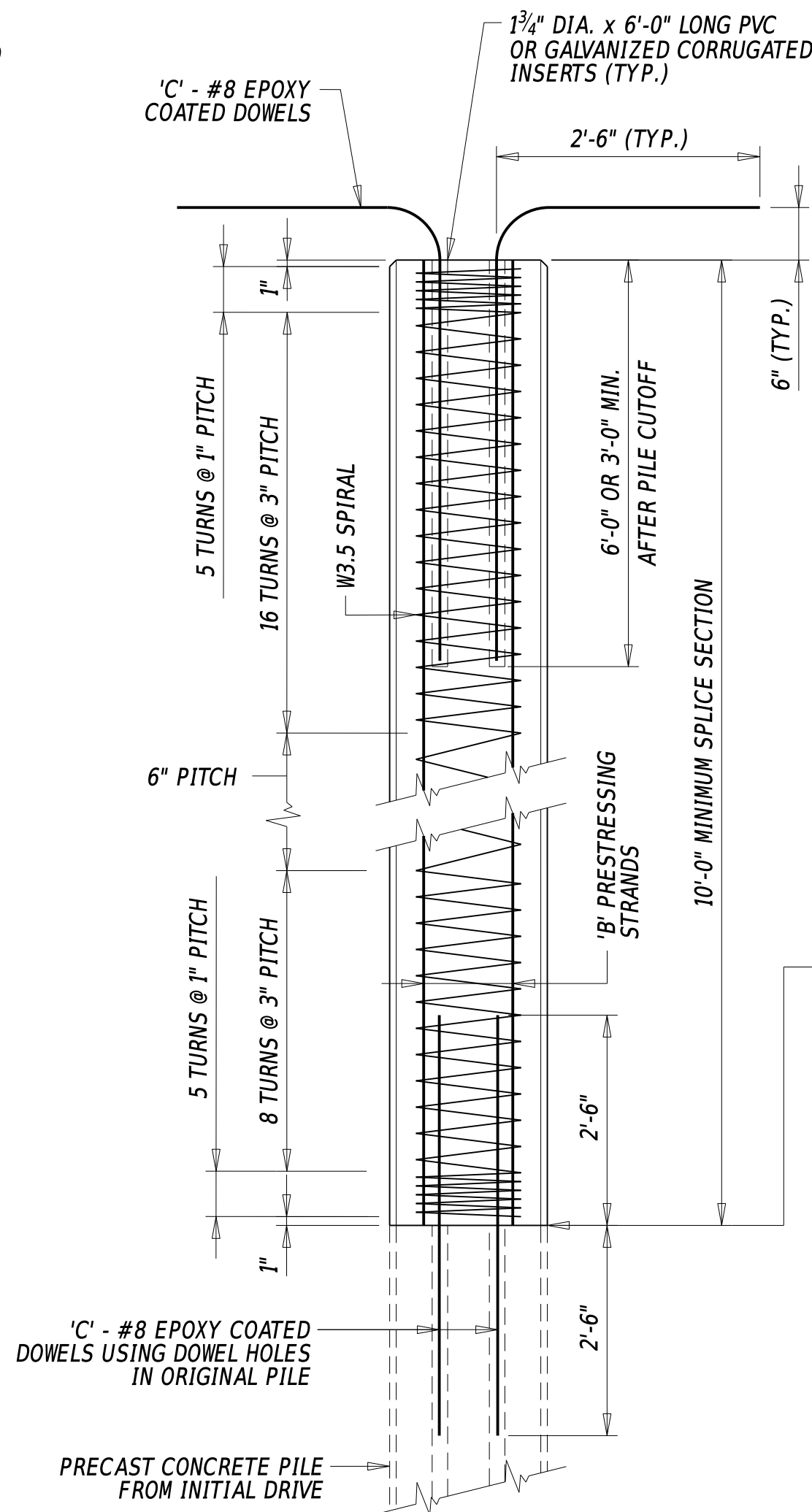

PILE BUILD-UP FOR DRIVING (PRECAST)

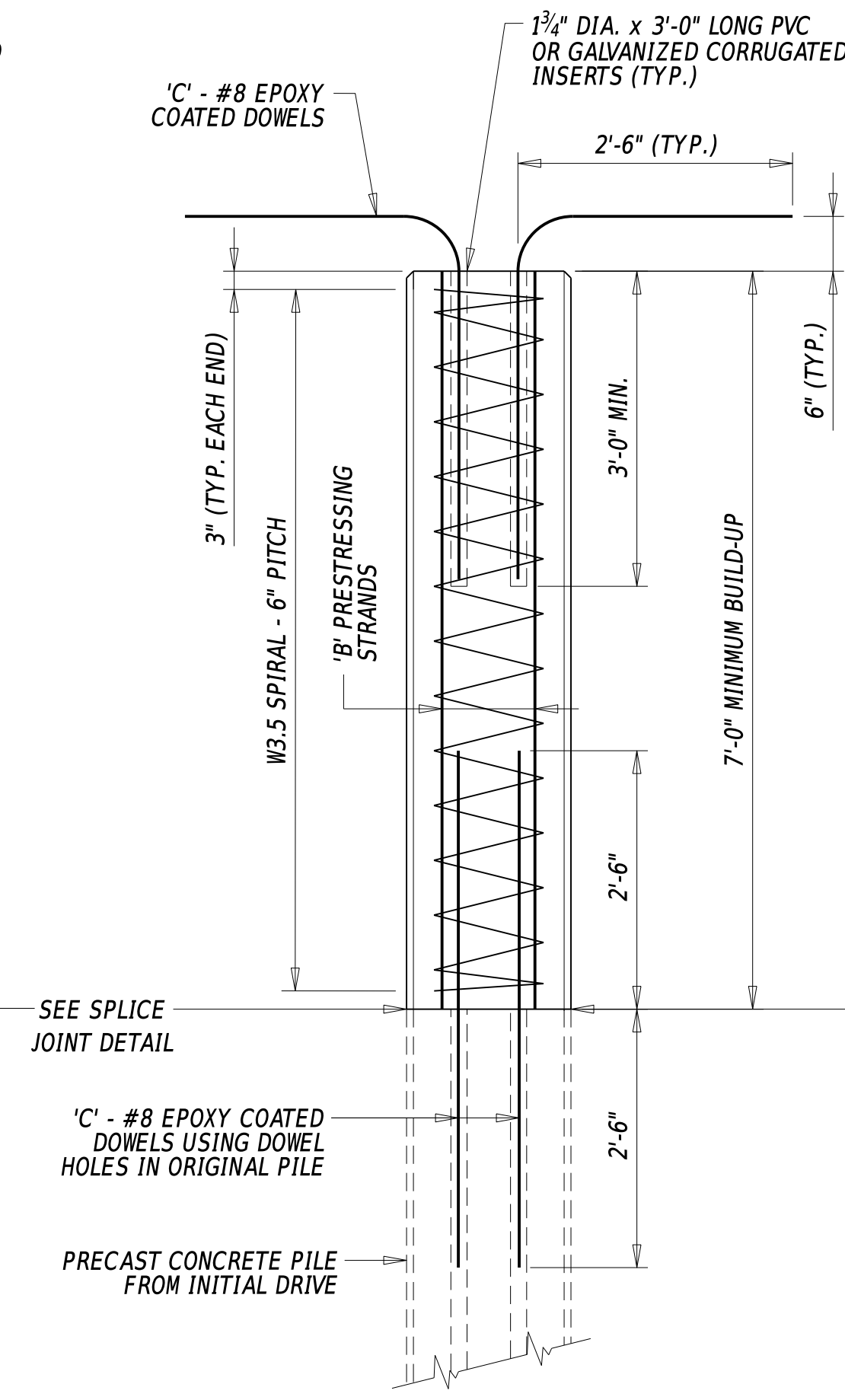

PILE BUILD-UP WITHOUT DRIVING (PRECAST)

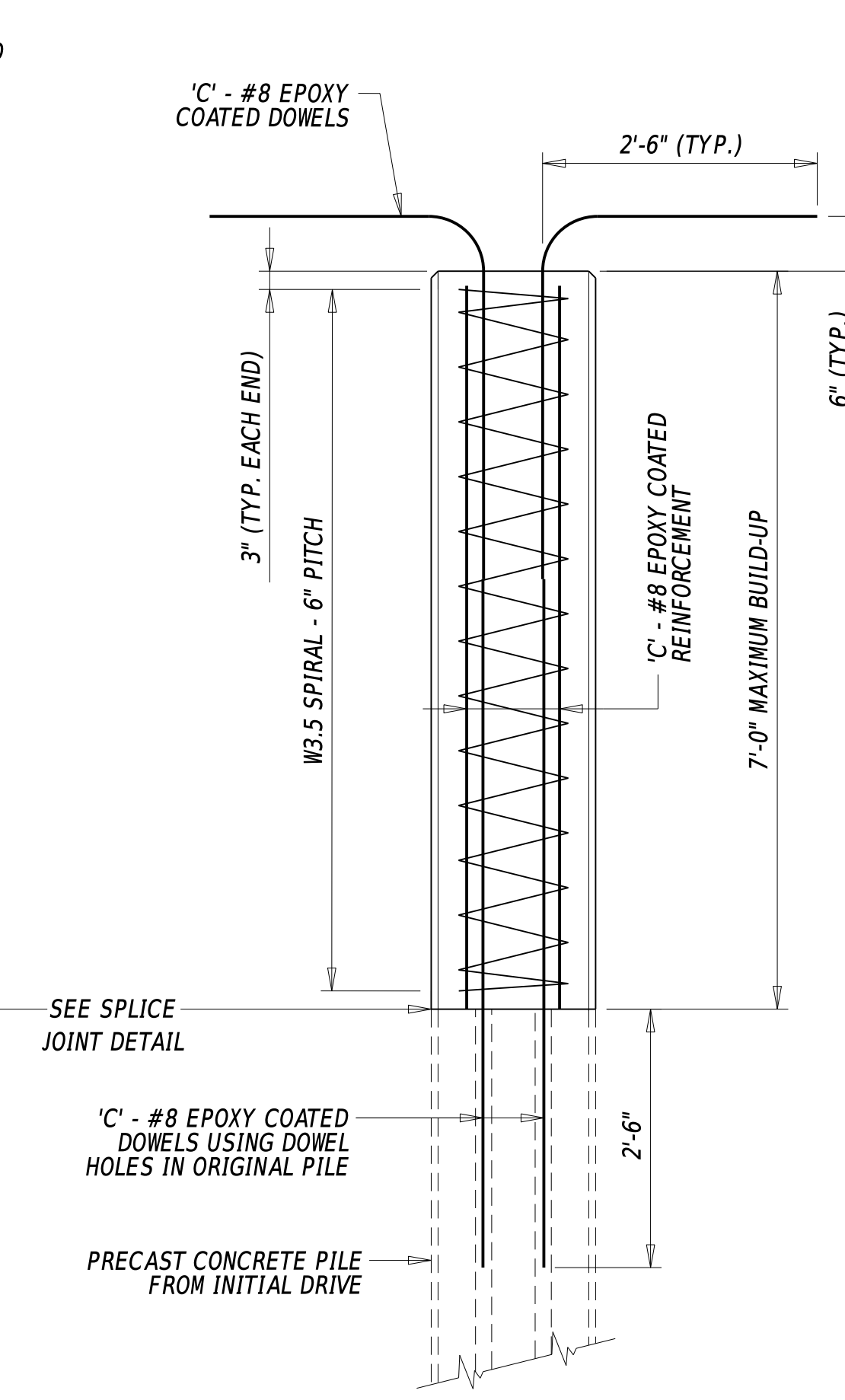

PILE BUILD-UP WITHOUT DRIVING (CAST-IN-PLACE)

PRECAST PRESTRESSED CONCRETE PILE SIZES		
PILE SIZE	STRANDS	DOWELS
'A'	'B'	'C'
12"	6	4
14"	8	4
16"	10	6
18"	12	8
20"	16	8
24"	24	12

PROJECT SPECIFIC PILE NOTES

- PILE TYPE: THIS PROJECT WILL UTILIZE ___" x ___" PRESTRESSED-PRECAST CONCRETE PILES.
- ESTIMATED PRODUCTION PILE LENGTH IS ___'. (See Designer Note 2)
- REQUIRED TEST PILE LENGTH IS ___' LONGER THAN THE ESTIMATED PRODUCTION PILE LENGTH. (See Designer Note 3)
- DRIVE PILES TO A BEARING RESISTANCE OF ___ KIPS USING A RESISTANCE FACTOR OF ___.
- MINIMUM TIP ELEVATION WILL NOT BE REQUIRED FOR THIS PROJECT or REFER TO THE PILE INSTALLATION DATA TABLE FOR MINIMUM TIP ELEVATION.
- DESIGN ASSUMPTIONS: THE PRESTRESSED CONCRETE PILES WERE DESIGNED FOR (NORMAL EXPOSURE or SEVERE CORROSIVE CONDITIONS).
- if using accelerated bridge construction, see Designer Note 12.

GENERAL PILE NOTES

- FOR MORE INFORMATION REGARDING PILE DRIVING, INSTALLATION, MATERIALS, AND FABRICATION, REFER TO SECTION 605 - DRIVEN PILES OF THE STANDARD SPECIFICATIONS.
- (See Designer Notes 2, 3 and 4)
(A) DRIVE TEST PILES AT EACH LOCATION SHOWN ON THE PLANS. PRODUCTION PILES WILL BE ORDERED BASED ON THE RESULTS OF THE TEST PILE DRIVING.
or
(B) ORDER SAME LENGTH FOR ALL PILES (i.e. WITHOUT A LONGER TEST PILE). TEST PILES, AS NOTED, WILL BE DRIVEN FIRST TO ESTABLISH DRIVING CRITERIA FOR THE OTHER PILES IN EACH SUBSTRUCTURE ELEMENT. AN ADDITIONAL ___' HAS BEEN ADDED TO THE DESIGN LENGTH OF EACH PILE AS A CONTINGENCY.

PRESTRESSED-PRECAST CONCRETE PILE NOTES

- PROTECT ALL REINFORCING STEEL WITH FUSION BONDED EPOXY.
- EPOXY GROUT FOR GROUTING THE DOWEL BARS IN THE TOP OF THE PRESTRESSED-PRECAST CONCRETE PILE MUST BE AN APPROVED NON-SHRINK EPOXY GROUT SPECIFICALLY DESIGNED AS A FAST SETTING COMPOUND THAT POURS EASILY TO FILL THE VOIDS. THE COST OF GROUTING THE DOWEL BARS IS INCIDENTAL TO THE RESPECTIVE PILE.
- THE CONTRACTOR MAY CONSIDER USING ALTERNATIVE PILE BUILD-UP DETAILS FOR BOTH DRIVING AND WITHOUT DRIVING. SUBMIT ALTERNATIVE DETAILS FOR PILE BUILD-UPS TO THE DEPARTMENT FOR APPROVAL.
- THE CONTRACTOR MAY CONSIDER USING ALTERNATIVE SPLICE JOINT DETAIL. SUBMIT ALTERNATIVE DETAILS FOR SPLICE JOINT TO THE DEPARTMENT FOR APPROVAL.

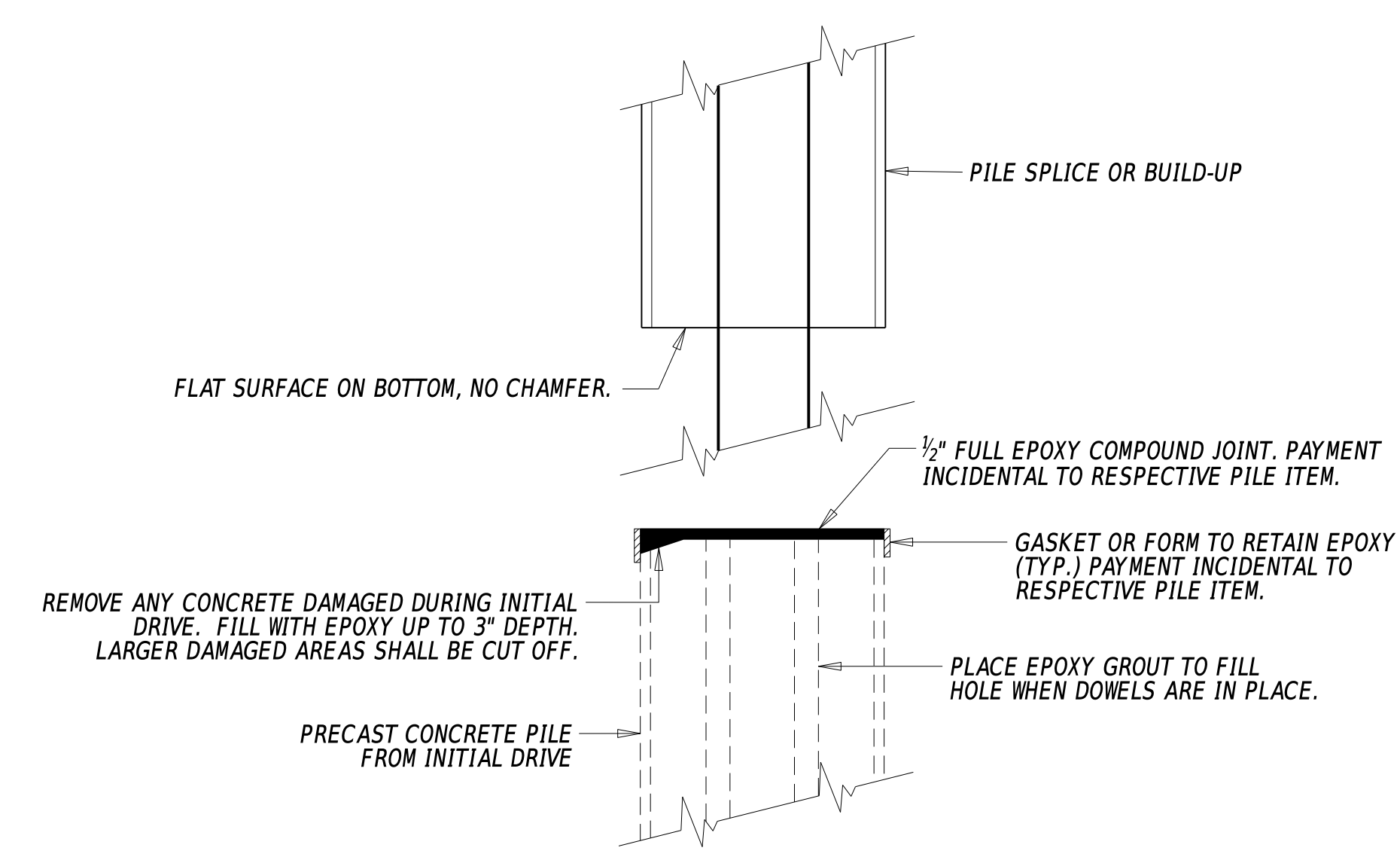

SPLICE JOINT DETAIL

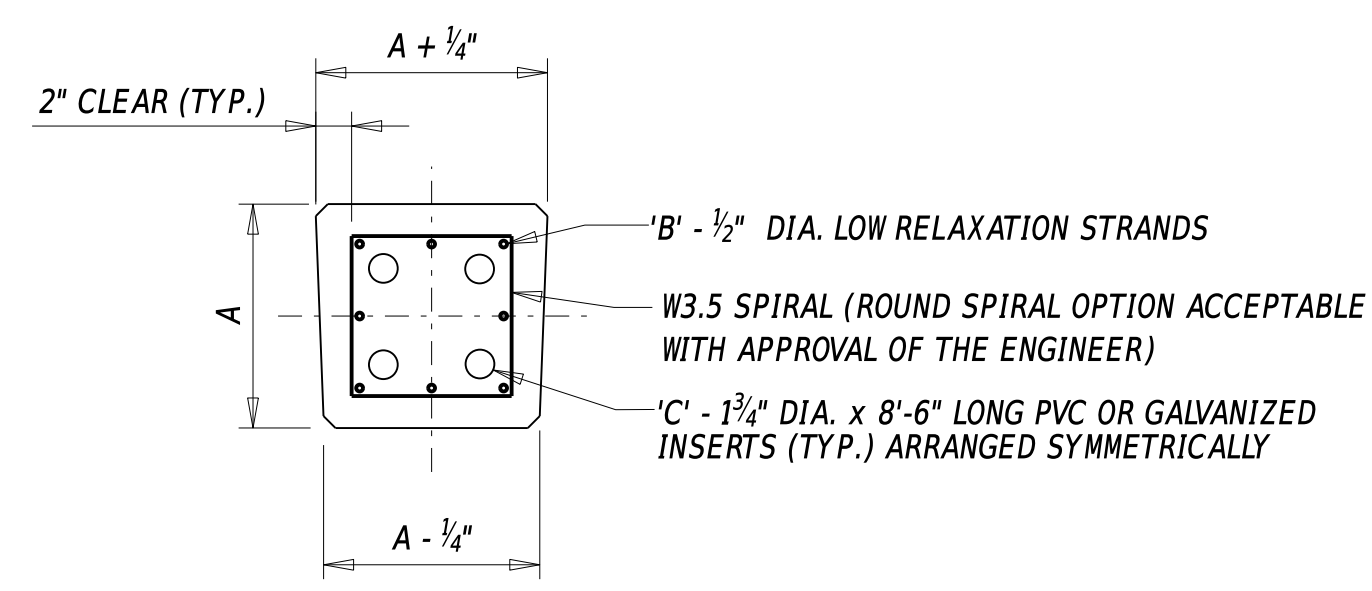

TYPICAL PRECAST PILE SECTION

SUBSTRUCTURE UNIT	DESIGN DATA		ACTUAL FIELD DATA		
	MINIMUM TIP ELEVATION	ESTIMATED PILE TIP ELEVATION	ACTUAL MINIMUM TIP ELEVATION	ACTUAL AVERAGE TIP ELEVATION	ACTUAL MAXIMUM TIP ELEVATION

(See Designer Note 6)

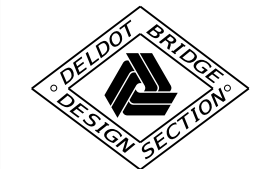

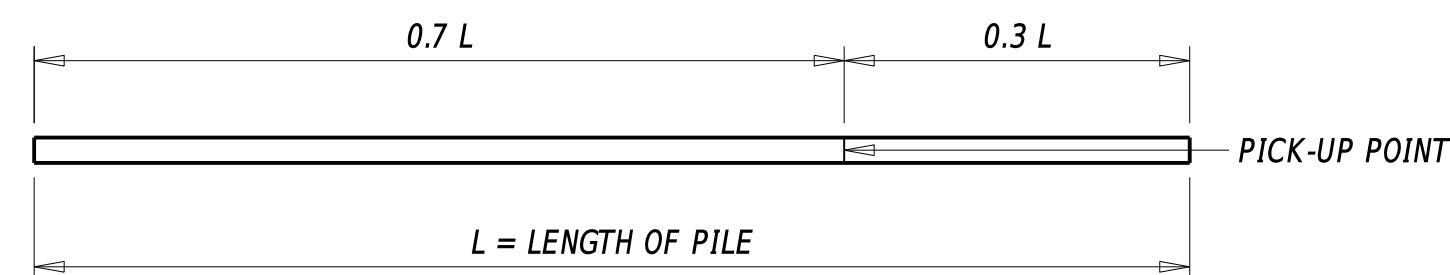

1-POINT

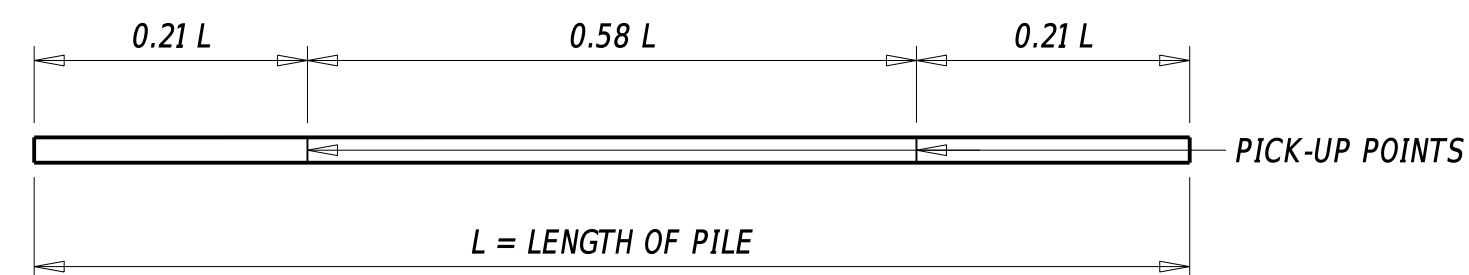

2-POINT

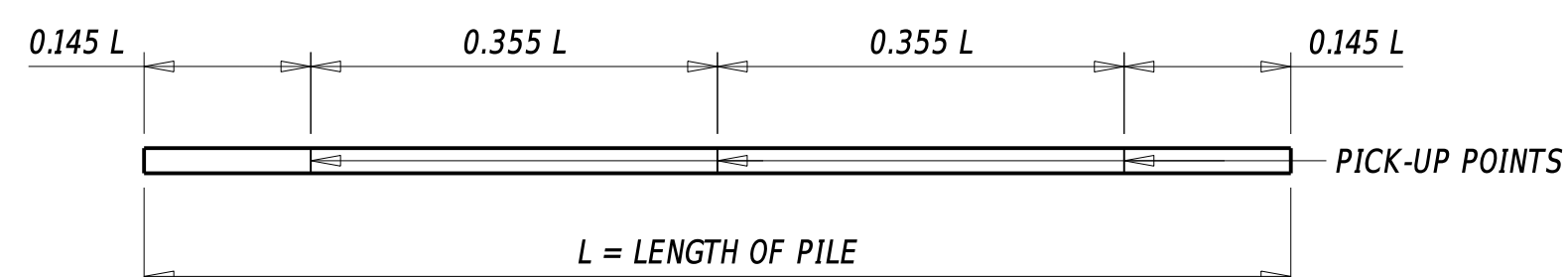

3-POINT

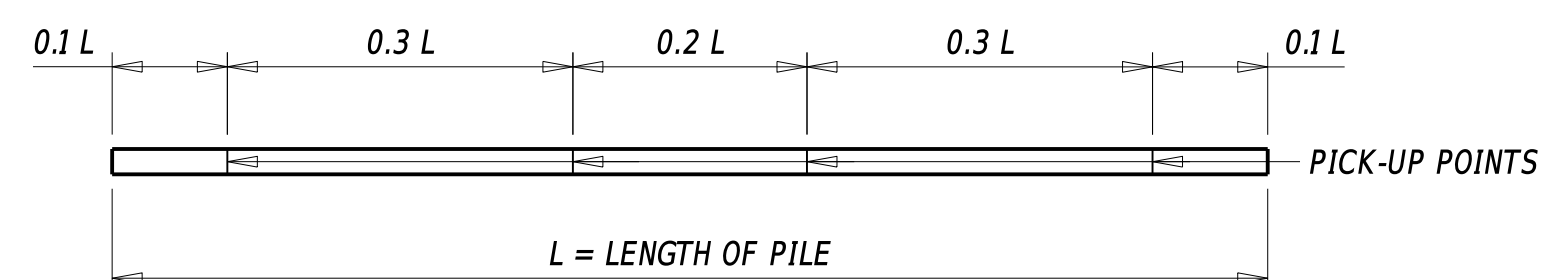

4-POINT

PICK-UP DIAGRAMS

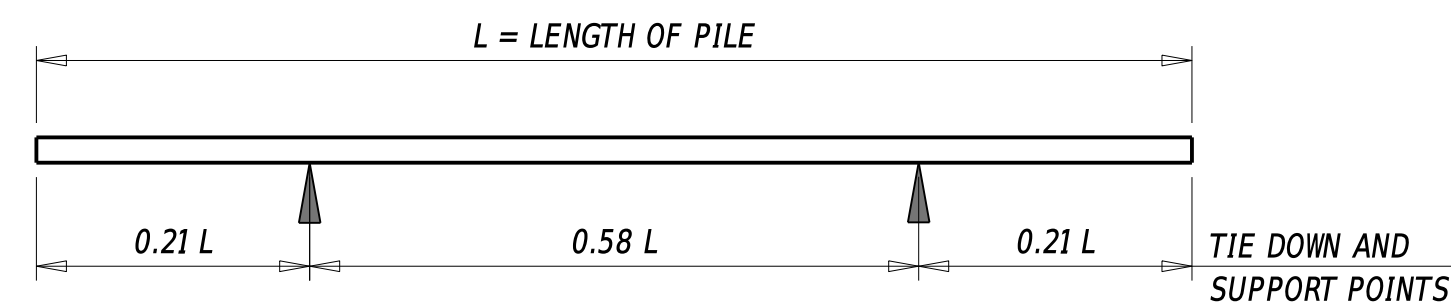

2-POINT

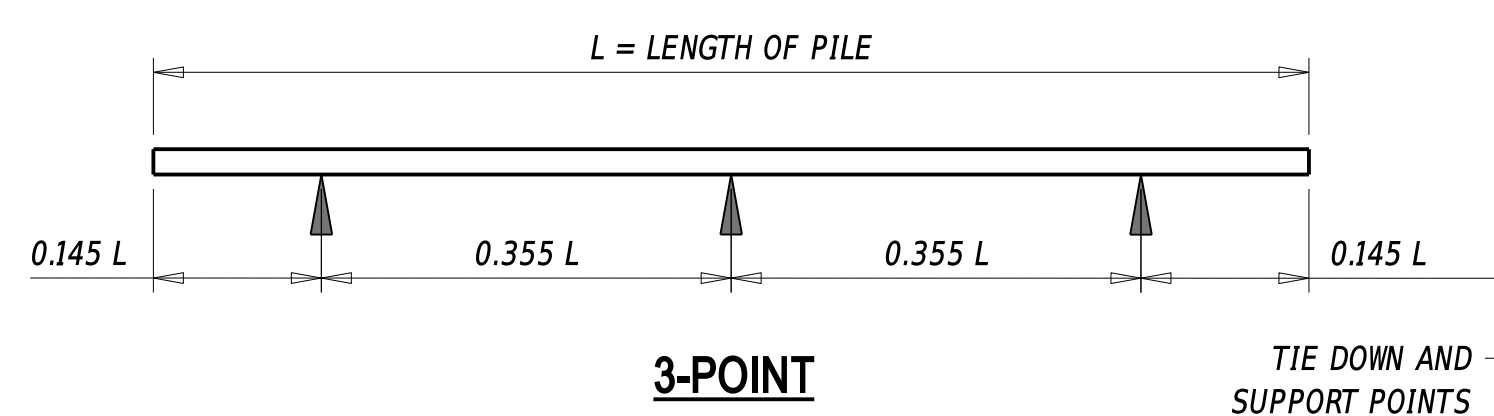

3-POINT

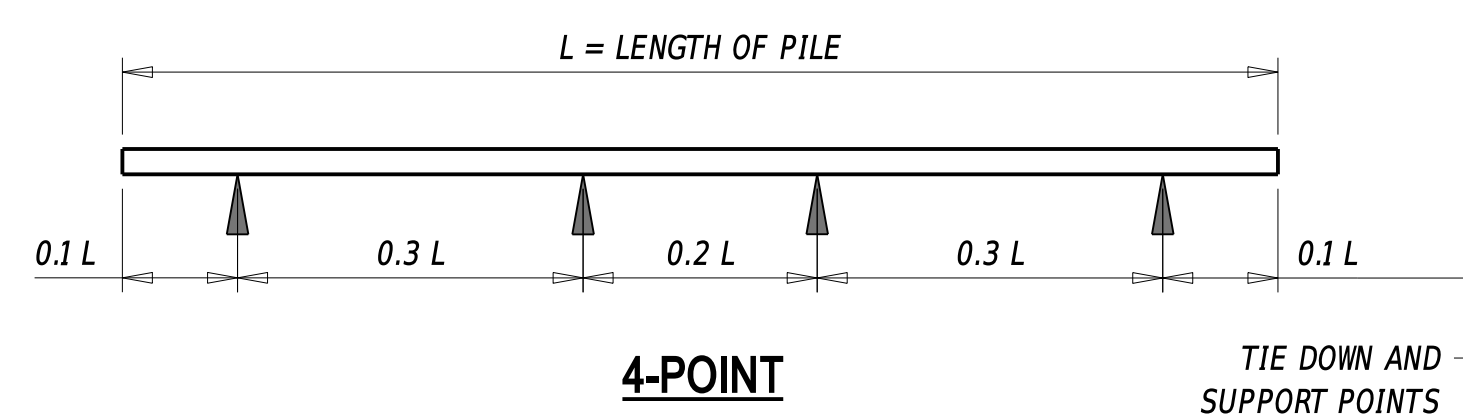

4-POINT

SUPPORT DIAGRAMS FOR STORAGE AND TRANSPORTATION

MAXIMUM PILE PICK-UP AND SUPPORT LENGTHS							
PICK-UP METHOD	PILE SIZE 12"	PILE SIZE 14"	PILE SIZE 16"	PILE SIZE 18"	PILE SIZE 20"	PILE SIZE 24"	REQUIRED SUPPORT METHOD
1-POINT	62'	67'	70'	73'	79'	88'	2, 3, OR 4-POINT
2-POINT	88'	94'	99'	103'	112'	125'	2, 3, OR 4-POINT
3-POINT	126'	135'	142'	148'	160'	179'	3 OR 4-POINT
4-POINT	177'	189'	199'	207'	225'	250'	4-POINT

NOTE:

1. THE PICK-UP DIAGRAMS, SUPPORT DIAGRAMS FOR STORAGE AND TRANSPORTATION, AND THE 'MAXIMUM PILE PICK-UP AND SUPPORT LENGTHS' TABLE ARE FOR INFORMATION PURPOSES ONLY AND SHOULD NOT BE INCLUDED ON THE PLAN SET.
2. THE 'MAXIMUM PILE PICK-UP AND SUPPORT LENGTHS' TABLE IS BASED ON THE COMPRESSIVE STRENGTH (f'_{ci}) AT THE TIME OF INITIAL RELEASE AT 4800 psi.
3. THE DESIGNER MUST CONSIDER THE POSSIBILITY THAT THE CONTRACTOR WILL POSITION PILE INTO PLACE FOR DRIVING USING THE ONE-POINT PICK-UP METHOD. THEREFORE IT IS RECOMMENDED THAT THE PILE LENGTH BE LIMITED TO THE MAXIMUM LENGTH FOR THE ONE-POINT PICK-UP METHOD.

DESIGNER NOTES

1. 'PROJECT SPECIFIC PILE NOTES', 'GENERAL PILE NOTES', AND 'PRESTRESSED-PRECAST CONCRETE PILE NOTES' ARE REQUIRED TO BE SHOWN ON THE PLAN SETS.
2. UNDER 'PROJECT SPECIFIC PILE NOTES', NOTE 2, THE ESTIMATED PRODUCTION PILE LENGTH SHOULD BE EQUAL TO THE ESTIMATED DESIGN PILE LENGTH IF 'GENERAL PILE NOTES', NOTE 2(A) IS USED. IF 'GENERAL PILE NOTES', NOTE 2(B) IS USED, THEN THE ESTIMATED PRODUCTION PILE LENGTH SHOULD BE EQUAL TO THE ESTIMATED DESIGN PILE LENGTH + 5'-0".
3. UNDER 'PROJECT SPECIFIC PILE NOTES', NOTE 3, THE REQUIRED TEST PILE LENGTH SHOULD BE 10'-0" LONGER THAN THE ESTIMATED PRODUCTION PILE LENGTH IF 'GENERAL PILE NOTES', NOTE 2(A) IS USED. IF 'GENERAL PILE NOTES', NOTE 2(B) IS USED, THEN THE REQUIRED TEST PILE LENGTH SHOULD BE EQUAL TO THE ESTIMATED PRODUCTION PILE LENGTH + 5'-0".
4. UNDER 'GENERAL PILE NOTES', NOTE 2, THE DESIGNER MUST CHOOSE BETWEEN 2(A) AND 2(B) AND DELETE THE NOTE CONTAINING THE METHOD NOT USED FOR THE PROJECT. METHOD 2(A) SHOULD BE USED IF THERE IS SUFFICIENT TIME FOR THE CONTRACTOR TO ORDER PRODUCTION PILES BASED ON TEST PILE RESULTS. THIS TYPICALLY APPLIES ONLY TO LARGER-SIZED PROJECTS OR WHEN PILE DRIVING IS NOT THE CRITICAL PATH. METHOD 2(B) IS MORE COMMON DUE TO TIME CONSTRAINTS IN THE CONSTRUCTION SCHEDULE AND THEREFORE IS USED FOR MAJORITY OF DELDOT PROJECTS.
5. AS PER SECTION 612 - PRECAST CONCRETE OF THE STANDARD SPECIFICATIONS, UNLESS OTHERWISE NOTED ON THE PLANS, THE 28-DAY COMPRESSIVE STRENGTH (f'_{c}) OF THE PRESTRESSED-PRECAST CONCRETE PILE IS ASSUMED TO BE 6000 psi WITH A COMPRESSIVE STRENGTH (f'_{ci}) AT THE TIME OF INITIAL RELEASE AT 4800 psi.
6. THE 'PILE INSTALLATION DATA' TABLE SHOULD BE USED FOR ALL PROJECTS. IF MINIMUM TIP ELEVATION IS NOT REQUIRED FOR THE PROJECT, THE DESIGNER SHOULD SIMPLY PLACE 'N/A' UNDER THE 'MINIMUM TIP ELEVATION' COLUMN. THE 'ACTUAL FIELD DATA' INFORMATION SHOULD BE FILLED OUT BY THE FIELD INSPECTOR AND INCLUDED IN THE AS-BUILT DRAWINGS.
7. THE DESIGNER MUST EVALUATE THE STRUCTURAL CAPACITY OF THE PILE FOR ANTICIPATED DRIVING CONDITIONS AND WHEN STRENGTH I LOADS ARE APPLIED TO THE PILES AS PART OF PILE SIZING SELECTION.
8. THE PILE BUILD-UP AND SPLICE JOINT DETAILS AS SHOWN ON SHEET 1 ARE RECOMMENDED. THE CONTRACTOR SHOULD BE ENCOURAGED TO SUBMIT ALTERNATIVE DETAILS IF SUCH DETAILS REDUCES CONSTRUCTION TIME AND/OR THE TOTAL CONSTRUCTION COSTS.
9. THE DESIGNER MUST DETERMINE WHETHER THE PILE BE CLASSIFIED AS 'FREE HEAD' OR 'FIXED HEAD'.
 - (a) STANDARD DELDOT PRACTICE REQUIRES THE TOP OF PILE TO PROJECT A MINIMUM OF 12" INTO THE PILE CAP AFTER ALL DAMAGED MATERIAL HAS BEEN REMOVED WHILE MEETING REQUIRED QUANTITY OF DOWELS 'C' IN THE TABLE PROVIDED ON SHEET 1. PILES MEETING THESE MINIMUM REQUIREMENTS WILL BE CONSIDERED AS 'FREE HEAD'.
 - (b) FOR A PILE TO BE CLASSIFIED AS 'FIXED HEAD', THE PILE MUST MEET ALL THE REQUIREMENTS AS SPECIFIED IN 9(a) WITH EXCEPTION THAT TOP OF PILE MUST PROJECT INTO THE PILE CAP A MINIMUM OF 2*PILE DIA. AFTER ALL DAMAGED MATERIAL HAVE BEEN REMOVED.
10. FOR PILE BENTS, THE DESIGNER MUST DETERMINE THE POINT OF FIXITY AS PER A10.7.3.13 AND SECTION 107.5.4. FURTHERMORE, THE DESIGNER MUST CONSIDER THE SLENDERNESS RATIO WHEN SELECTING THE PILE SIZE FOR BOTH PRODUCTION AND TEST PILES.
11. REFER TO SECTION 107.3.4.1 FOR MORE INFORMATION ON PRESTRESSED-PRECAST CONCRETE PILES.
12. FOR CERTAIN TYPES OF CONSTRUCTION SUCH AS ACCELERATED BRIDGE CONSTRUCTION WITH PRECAST CONCRETE SUBSTRUCTURES, CONSIDER ADDING A NEW NOTE UNDER 'PROJECT SPECIFIC PILE NOTES' ASSIGNING A VALUE OF LESS THAN 3 INCHES SPECIFIED IN SECTION 605.3.4.B.9 OF STANDARD SPECIFICATIONS FOR MAXIMUM ALLOWABLE VARIATION AT THE TOP OF THE PILE IN ANY DIRECTION FROM THE LOCATION SHOWN IN THE CONTRACT DOCUMENTS.

